

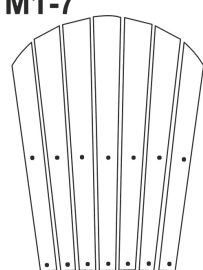

M1-7



C





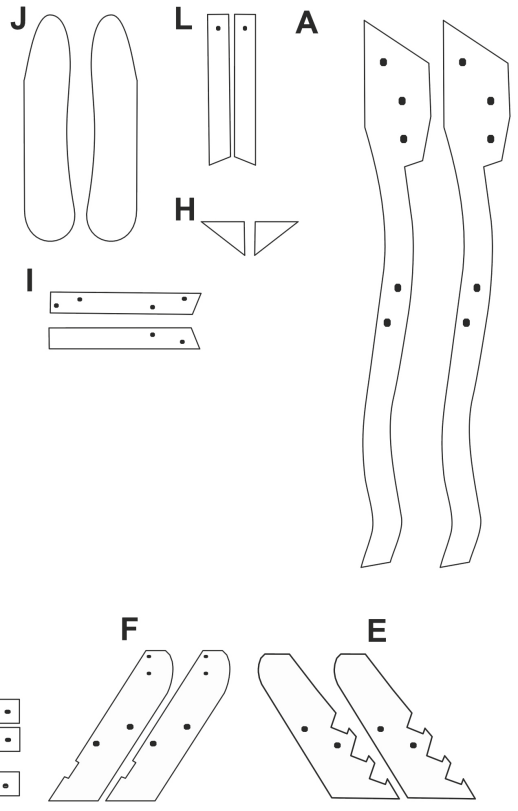

B1-15

• 1 •
• 2 •
• 3 •
• 4 •
• 5 •
• 6 •
• 7 •
• 8 •
• 9 •
• 10 •
• 11 •
• 12 •
• 13 •
• 14 •
• 15 •

Pièce	Quantité
A	2
B	15
C	1
D	1
E	2
F	2
G	2
H	2
I	2
J	2
K	1
L	2
M	1
N	7



-  4 x large screws
-  20 x washers
-  8 x bolts and 8 x nuts
-  64 x 4x40 mm screws
-  6 x 4x30 mm screws

TEN STEPS TO THAT COMFY CHAIR FEELING

To gain maximum enjoyment from your Comfy Chair, assemble the chair according to the instructions in this sheet. For more strength and stability, we advise glueing the joints with the water resistant wood adhesive supplied.

STEP 1

Lay the sidepieces (A) on a flat surface with the notches facing upwards. Take one of the slats (B) and place it in the first notches at the front of parts (A). Make sure that the countersunk edge of the pre-drilled holes is facing upwards. Secure the slat on each side with a 4x40 mm screw. Now take a second (B) slat and secure this in the same way into the one of the notches near the back. Make sure that the outermost edges of the slats are precisely aligned with the outermost edges of the notches and that the countersunk edges of the pre-drilled holes are facing upwards again. When the construction is upright, place the slat with the Comfy logo on the front into the second set of notches and secure in the same way as for the other (B) slats.

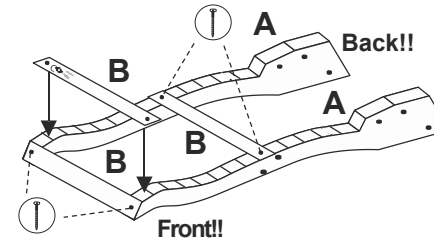

STEP 2

Secure all the remaining slats (B) 1 -15 and, lastly, the curved plank (C). Make sure that the curved side is facing the back. Now fix the low rear support (C) between the two sidepieces (A). Take two washers and two large screws. Slide a washer over each large screw. Push the large screws from the outside on the right and left through the large holes at the back of sidepieces (A). Place part (K) in the middle and secure it. Make sure that the plank is precisely in the middle. Do not tighten the screws yet. Plank (K) must be able to be turned round.

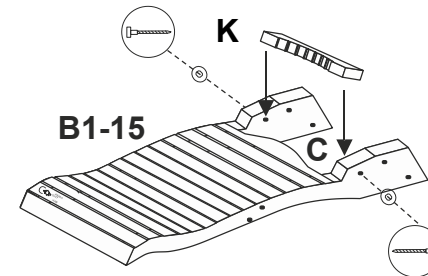

STEP 3

Set four bolts and washers in the large holes at the front and in the middle of parts (A). Now secure the legs (E) and (F) on the outside of part (A). Slide the bolt and the washer from the outside through parts (E) and (F). Fasten with the nuts and washer from the inside. Repeat on the other side of the reclining chair.

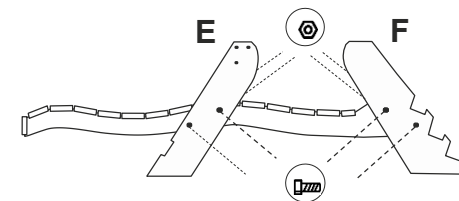

STEP 4

Fasten the cross bars (G) to the front and back legs. Place one (G) plank underneath the lowest notches beneath the back legs. Do the same with the other (G) plank under the front legs. Use a 4x40 mm screw on each side of the planks.

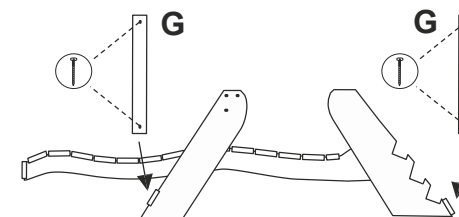

STEP 5

The next step is to construct the armrests. It is important to glue all of these parts. Fasten the armrest (I) on the outside of leg (E) and (F) using one 4x40 mm screw on each leg. The top of (I) should be flush with the top of (E) and (F). Now take triangle (H) and set this underneath part (I) of the front leg (E). Fasten it using a 4x40 mm screw to leg (E) and to part (I) in the pre-drilled holes.

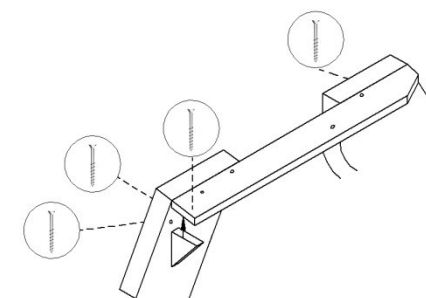

STEP 6

Place the armrest (J) facing the right direction on top of the 'armrest frame'. Attach it using three 4x30 mm screws. Tighten the screws through plank (I) from underneath. Repeat step 5 and 6 on the other side of the reclining chair.

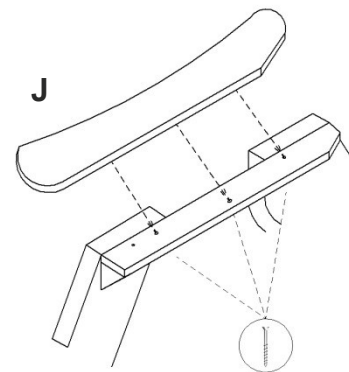

STEP 7

Now put the 'position stopper' together. Set the parts (L) onto the right and left side of the upper back support (D). Fasten the planks through the hole on the top of planks (L) using a large screw and a washer. Do NOT over tighten the screws! Part (D) must still be flexible. Now place slat (M) underneath part (I) and secure it using a 4x40 mm screw on each side.

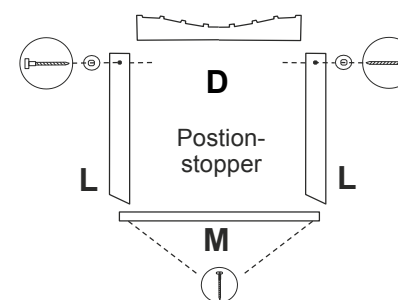

STEP 8

Hold the 'position stopper' facing the front of the reclining chair and set it upright into the last reclining position underneath the back legs. Slat (M) should sit perfectly in the notch. Turn the upper back support (D) until the notches are facing the front.

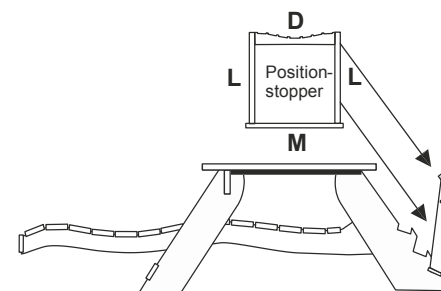

STEP 9

Now take all seven back slats. Lay the slats in the correct order, starting with the longest one in the middle. Lay three slats on each side so that the top of the backrest forms a curved line. The countersunk edges of the pre-drilled holes should face upwards. Take the middle, longest slat, fasten it with a 4x40 mm screw to the low rear support (D), and then to the upper back support (J). Make sure that the underside fits exactly in the notch and that the slat is parallel on the underside to the bottom of the low back support.

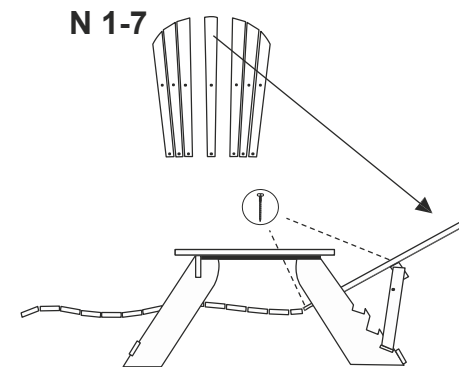

STEP 10

Now secure all the slats correctly to the underside of back support (D) using 4x40 mm screws. Do not fasten the screws at the top before checking that all slats are in the correct position and that the upper edge forms a nice, curved line. The spacing between the slats should be even. Use the notches as reference points. When all slats are correctly positioned, they can be secured at the top using 4x40 mm screws.

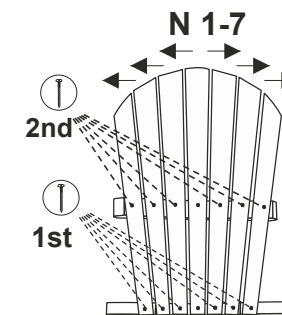

Sit back and enjoy the sun in your Comfy Sun Lounger!

Comfy Chair
Barneveld
Netherlands

Tel: + 0031 6 51920965

info@comfychair.nl | www.comfychair.nl

